



Quality Seed And Grain Equipment

Edible Bean Polisher



- Improve the Quality and Presentation of Edible Beans and Soybeans
- Available from 1 to 6 Box Configurations for Various Throughput Volumes
- Independent Motors for the Fan, Eccentric & Polishing Box Paddles
- Bean Matrix/Polishing Eccentric Screening and Return with Gentle Handling
- Vibratory Feed System on 3 through 6 Box Units Standard
- Easy access to polishing boxes and screens for clean-out and screen changes
- Heavy Duty Eccentric Assembly, all components are CNC Machined
- TEFC, NEMA Premium Efficient Motors; X-Proof Available
- Precision Fan Damper Controls

Other Options: 50 Hz Motors, Collection/Discharge Spouting Packages, SUB-Frames, Fan Transitions & “Wye” Pants, Tailored to accept Competitor Screens, EP-1 or 2: Discharge Aspiration with or without fan, Customized Machine Floor Plan, ETC.

2150 JBS Trail
Mt. Pleasant, MI, 48858
Phone: 989.775.2424



E-mail: info@q-sage.com
www.q-sage.com

Q-SAGE Model	HP Requirements					Capacity - BPH Beans
	Eccentric	Fan	Feed	Boxes	Bucket Elevator	
EBP - 1	1	N/A	N/A	1.5	0.5	50 - 100
EBP - 2	1.5	N/A	N/A	(2) @ 1.5	0.5	100 - 200
EBP - 3	2	5	1	3	0.75	150 - 300
EBP - 4	3	5 / 7.5	1	5	0.75	200 - 400
EBP - 5	3	5 / 7.5	1	5	0.75	250 - 500
EBP - 6	3	10 / 15	1	(2) @ 3	0.75	300 - 600

Suggested Polishing Media

- Sized Corn Cob Grit
- Dry Sawdust, Corn Meal, etc., may be experimented with

Polishing Media Mixes	Polishing Notes
Water / Cob Grit Mixture	General dirt/dust removal
Vinegar / Water / Cob Grit Mixture	General dirt/dust and stain removal
Veg Oil / Vinegar / Water / Cob Grit	General dirt/dust and stain removal + sheen

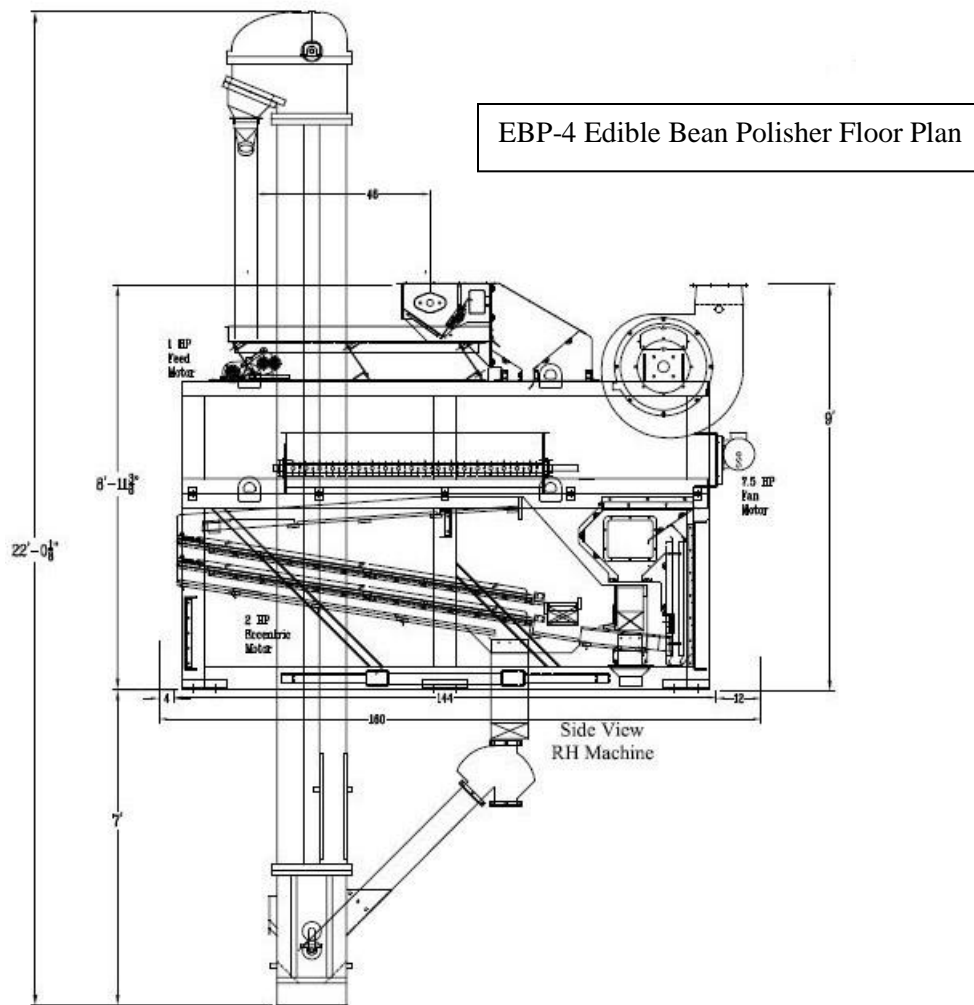

Quality Seed And Grain Equipment