



Quality Seed And Grain Equipment

Debearder



Product Features and Capabilities:

- Rub, De-awn, & Polish a Variety of Seed to Increase their Test Weight & Value
- Heavy Wall Drum Design for Superior Longevity
- Hardened Steel Paddles
- Industry Standard 15° Angle on Paddles to Rub & Assist with Product Flow
- TEFC, NEMA Premium Efficient Motors; X-Proof Available
- Dust Hood at Discharge of Machine for Containment
- Optional VFD (Variable Frequency Drive) for Easy RPM Adjustment
- 8" + 10" Drums utilize Pneumatic Clean-out
- 15" + 20" Drums utilize Heavy-Duty Drop-out Door for Easy Clean-out
- Use with Cereals, Turf, Forage & Prairie Grass Seed, Wild Flower, Malted Barley
- Numerous Models with Various Through-put Capacities Available
- Designed and Made in the USA

2150 JBS Trail
Mt. Pleasant, MI, 48858
Phone: 989.775.2424



E-mail: info@q-sage.com
www.q-sage.com

Q-SAGE Debearder

Q-SAGE Model	Capacity Approx. (BPH, Barley)	HP Req.	Clean Out	Discharge Spout w/ Dust Port
QD-8x18	50-100	3	Pneumatic	Included
QD-10x24	100-200	3 or 5	Pneumatic	Included
QD-10x36	150-300	5 or 7.5	Pneumatic	Included
QD-15x48	200-500	10 or 15	Bottom Gate	Included
QD-15x72	350-600	20 or 25	Bottom Gate	Included
QD-20x48	350-650	15 or 20	Bottom Gate	Included
QD-20x72	400-700	20 or 25	Bottom Gate	Included

Product Flow

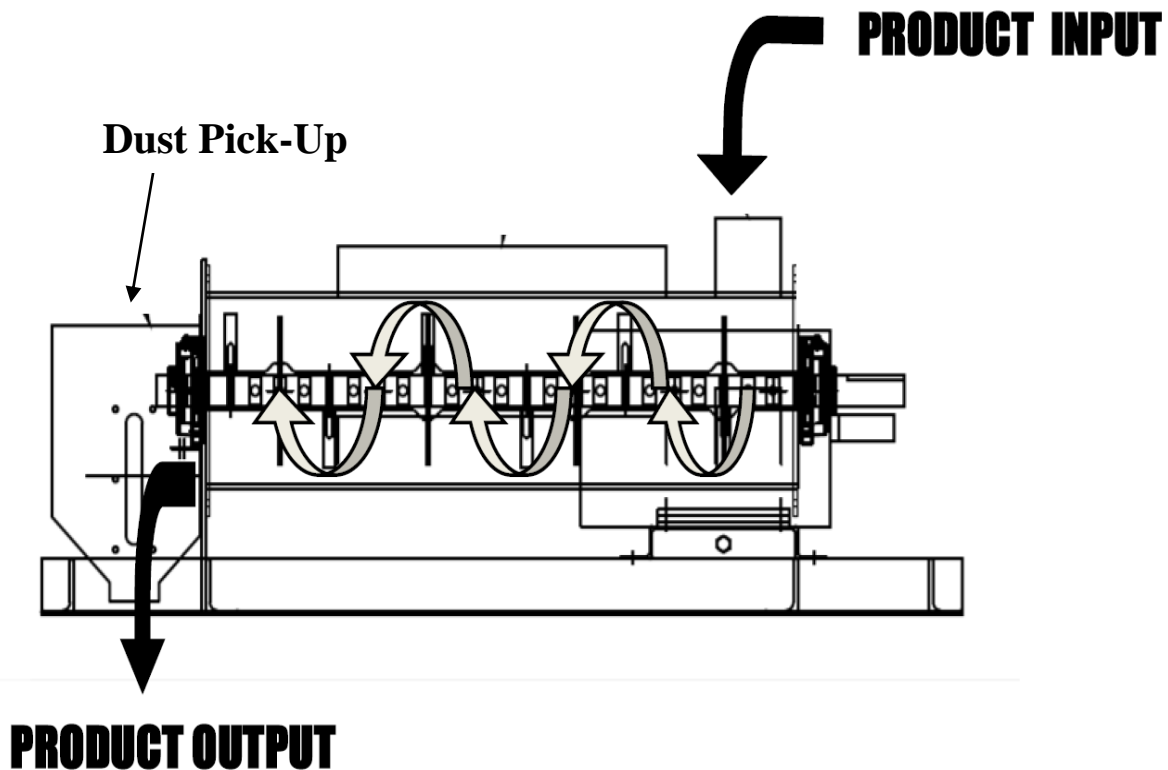

Quality Seed And Grain Equipment